



SINGLE-END-SIZING SYSTEM

TSE30F *FILAMENT SIZING MACHINE*

TSD30F *SUPPLY STAND*

TB30F *BEAMER*

TW30F *WARPER*

TCR-H/TCR-HT *CREEL*

TSE30F FILAMENT SIZING MACHINE

Evolving sizing machine

Low-tension control to softly treat delicate yarns

The motors and our unique control technology stably control the tension from the lowest 40 N. The low tension control is especially efficient for delicate yarns like fine yarns and a small lot. The machine also operates with stable tension during acceleration and deceleration.

NEW

Fluorine resin-coated tension roll in the cylinder section

When sized yarns are not sufficiently dried in the hot-air drying chambers or the cylinder section, size drips from the yarns and accumulates on the tension roll, resulting in easy yarn breakage. In order to prevent size accumulation, a fluorine resin-coated guide roll is employed. This reduces yarn breakage.

NEW

Stretch/tension control changeable device

Control for the yarn sheet in the hot-air drying chambers can be switched between the stretch control and the tension control as needed. For yarn types that have different proper stretch depending on the yarn speed, selecting the tension control holds the tension in the hot-air drying chambers constant.

NEW

Control box with a cooling device

The control box is provided with the cooling device that keeps the inside of the control box at a suitable temperature and humidity. Hence, the life-span of the electric components is extended.

NEW



Beam cooling device

When concentrated size liquid is used, sized warp yarns tend to adhere to each other on the beam. By cooling the sized beam, the adhesion can be prevented. The cooling capacity is increased compared with the existing model.

NEW

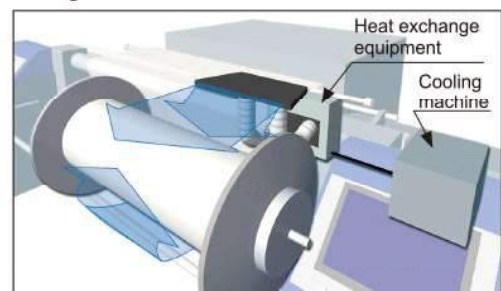

SINGLE-END-SIZING SYSTEM

Highly-insulated hot-air drying chambers **NEW**

The yarns are dried in the hot-air drying chambers without touching anything, keeping the surfaces of the yarns smooth and the body round.

The chambers of the TSE30F use the 2-step temperature control system. It keeps the temperature at 150 - 160°C for high speed operation and at 120 - 130°C for low speed operation. Thus, they can dry the yarns quickly without damaging the yarn properties. Moreover, a soft and gentle drying method is available. It dries at 80°C or less for sensitive yarns with a high thermal-shrinkage ratio. Heat insulation is enhanced compared with the existing model. Heat release from the sides is also reduced. This reduces steam consumption in the drying chambers by 4%.

The auto-tuning function of temperature control [PAT.] realizes stable temperature control [PAT.] in a wide range from high to low temperature.



*Accent color: Blue

Tension setting & control in increments of 1 N **NEW**

Tension setting & control in increments of 1 N is now possible instead of 10 N in the past. Tension suitable for yarn fineness can be set. This allows yarns to be sized while retaining their rate of elongation.

Alarm for size level in the size box **NEW**

Size level in the size box is monitored. When the size level lowers, the TSE30F is stopped by an alarm in order to prevent uneven size pick-up amount.

Automatic size supply **NEW**

Also, size level in the cavity box is monitored. When the level lowers, the size supply valve opens to allow size to enter the cavity box. It closes when the size level is sufficiently high.

Humidifying system in the split section **NEW**

Condensation builds up on the water-cooled split rods. This prevents size residue from adhering to the rods.



*Accent color: Indigo

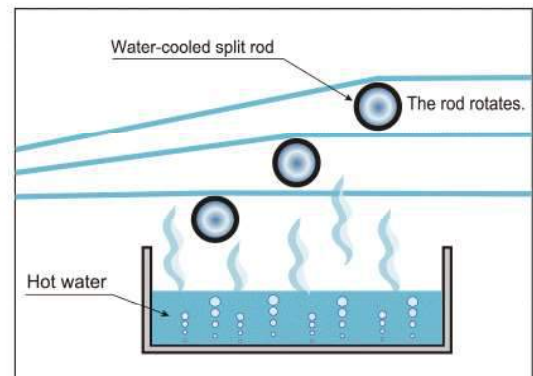
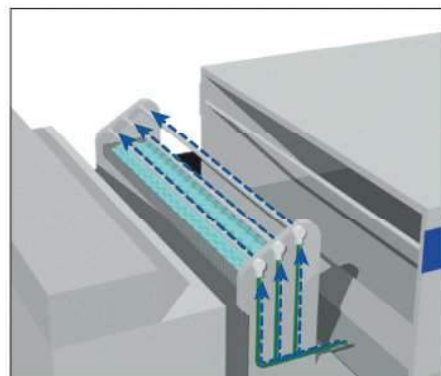

TSE30F FILAMENT SIZING MACHINE

High accuracy proves high quality.

Low tension control

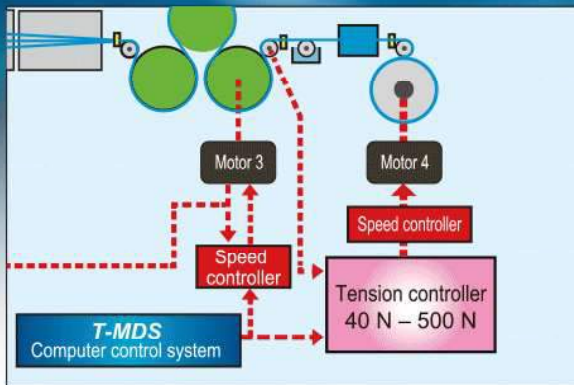

As the winding diameter increases, the change gear ratio between the cylinders and the take-up beam is adjusted so the take-up tension maintains the target value. This function stably controls the tension from the lowest 40 N and to the highest 500 N. Low tension control is especially efficient for delicate yarns like fine yarns and a small lot. The TSE30F operates with stable tension during acceleration and deceleration.

Multi-section drive system

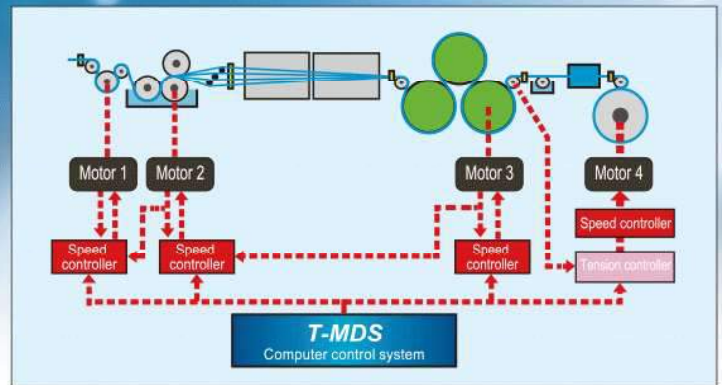

Filament yarns are widely classified depending on their kinds, texture, and fineness. Thus, the stretch setting has to be changed often when changing the production style. The multi-section drive system employs technology that synchronously operates multiple motors according to a certain ratio [PAT.]. Stretch is adjusted even during operation according to the yarn types and speed. Motor 1, Motor 2, and Motor 3 control the stretch for the feeding section, the sizing section, and the cylinder section respectively in 0.01 - 0.001% increments. Moreover, adjustments can be easily done while the sizing machine is in operation. Because of its ability to call up operating conditions, the T-MDS reproduces the same quality level of sized warps.

Uniform squeeze for quality sizing

On the TSE30F filament sizing machine, the squeeze roll has an iron core with a special shape. Thanks to this shape, no space is made at the center when both ends of the roll are pressed with air cylinders. Widthwise uniform pressure is achieved. A high pressure squeeze system of 15 kN is employed. The pressure is automatically controlled steplessly taking into account yarn speeds. By entering the respective target squeeze pressure for stop, low speed, and high speed, widthwise uniform squeeze can be achieved. The ideal roll arrangement and a large 180-liter cavity box prevent size from splashing and foaming.

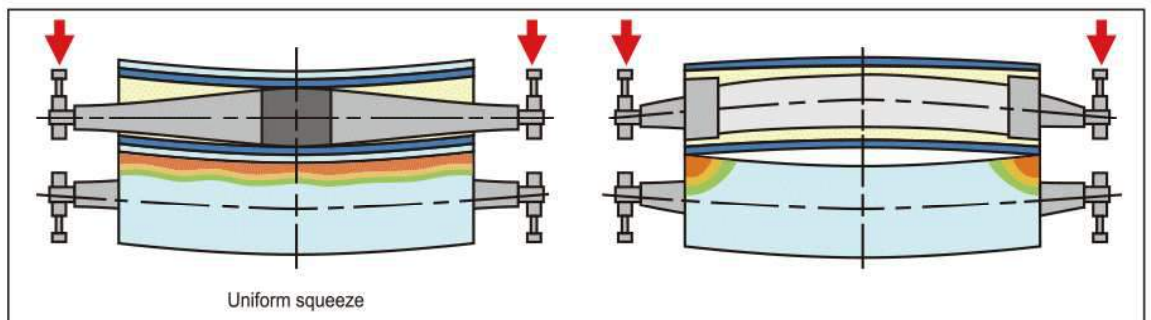
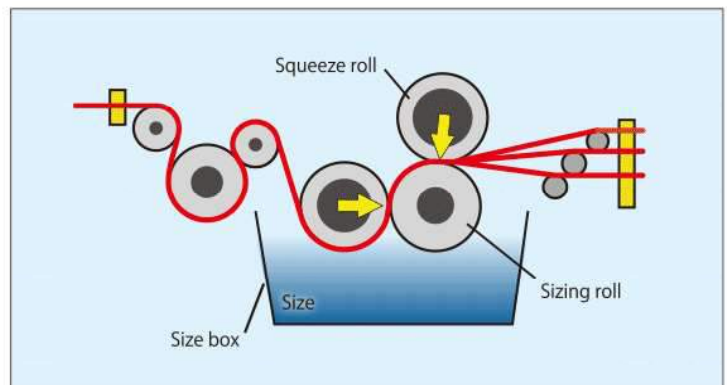

Customized functions for further specialization of abilities

Ultra-low tension control – **NEW** Accommodation for 20 N to 250 N (Option)

Setting 20 N to 250 N tension that meets yarn fineness is now possible. Yarns are taken up while keeping their rate of elongation. Therefore, removal of size coat on the yarns and fluff generation are reduced.

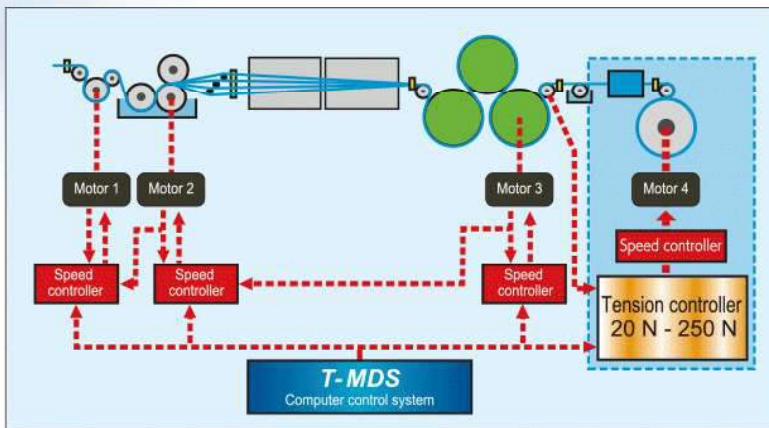

Advanced roll structure

Coupled with the tension control range from 20 N to 250 N, the roll structure is also advanced to adjust the tension suitable for the yarn fineness. This also supports ultra-low tension control.



*Accent color: Blue

Multi-point taper control for take-up tension **NEW** (Option)

This is efficient when there is a possibility that sized warp yarns adhere to each other on the beam. For example, when concentrated size is used. As the winding diameter increases, the take-up tension is lowered to lighten up tight winding.

Flocked roll (Option)



Nylon chips are contained in the synthetic rubber wound around the squeeze roll. This roll wipes excess size on the yarns. It contributes to more effective squeezing, preventing size beads on yarns, and enhancing weaving performance. It is also efficient for fine yarns.

Gas burner-type drying chamber (Option)

The TSE30F is efficient for yarns that require drying at temperatures of 200°C or more. For example, glass yarns. High to low temperature control is easy. Potential application for this specification is high. Because air is directly heated by gas combustion, thermal efficiency is high, and energy is saved.

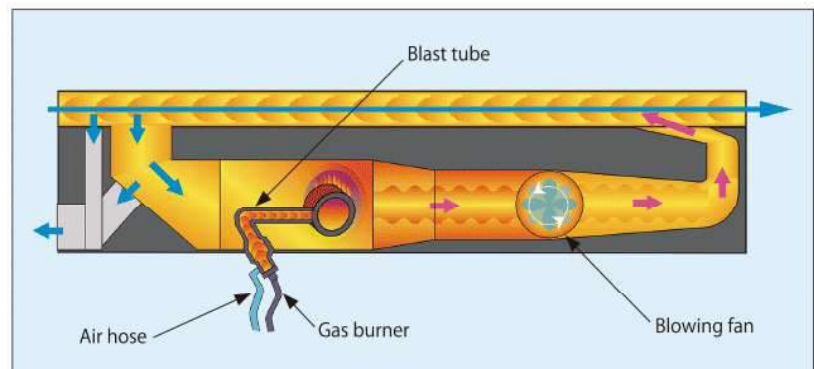

TSE30F

FILAMENT SIZING MACHINE

A wealth of options appropriate for yarn texture

Size pump inverter (Centrifugal pump) **(Option)**

Concentrated size foams easily. Such foaming is reduced to keep size conditions constant even by controlling the feed rate of size by the inverter.

Yarn speed following rotation of the water-cooled split rods **(Option)**

The split rods rotate at the appropriate speed in order to keep rod contact to the yarns unchanged. This makes size pick-up amount uniform since no excess water is contained by the yarns even while the TSE30F stops or operates at low speed.

Inverter-controlled comb traverse **(Option)**

Comb traverse shifts phases of the winding yarn sheet. The inverter-controlled comb traverse follows either yarn speed or winding diameter. This creates a well-arranged winding shape that results in less tension fluctuation. This is especially efficient for fine yarns.

Count-down counter **NEW** **(Option)**

This counter stops the machine where there is a defect found in the previous process. Repair work will be easy.

TSD30F

SUPPLY STAND

Following development

Tension setting & control in increments of 1 N **NEW**

Delicate yarns, such as super-fine yarns, require the tension to be set according to the yarn fineness. Setting in increments of 1 N allows finely-tuned setting and control. Stable rate of elongation is kept.

Stable tension control

There are no dancer rolls between the supply stand and the sizing machine, resulting in no snarling problem. High quality yarns are supplied by the sizing machine.

In case of a power failure, power supply to the motor stops. To prevent yarns from over-running due to the inertia of the beam, a mechanical brake works.

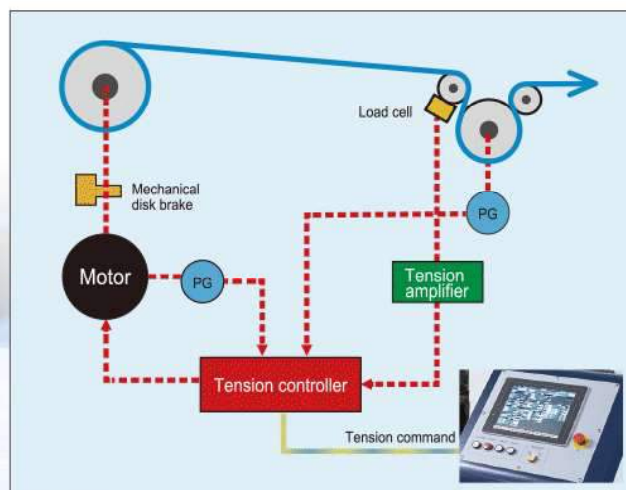

Note: The low-tension control for the lowest tension 20 N is also available as an option.

Pulling-out direction switchable function **(Option)**

The direction to pull-out the yarn sheet is switchable between "from above" and "from underneath." Adjusting the direction reduces warp streaks.

SINGLE-END-SIZING SYSTEM



Double supply stand (Option)

A double supply stand is available, if required. For example, when the number of spindles of the creel is small.

Safe work environment

When the lifting device is not provided:

A hoist is used when mounting or dismantling a warper's beam. Connection of the beam and the drive flanges is done manually.

Lifting device (Option)

The arm lifting device is used when mounting or removing a warper's beam. Connection of the beam and the drive flanges is done manually.

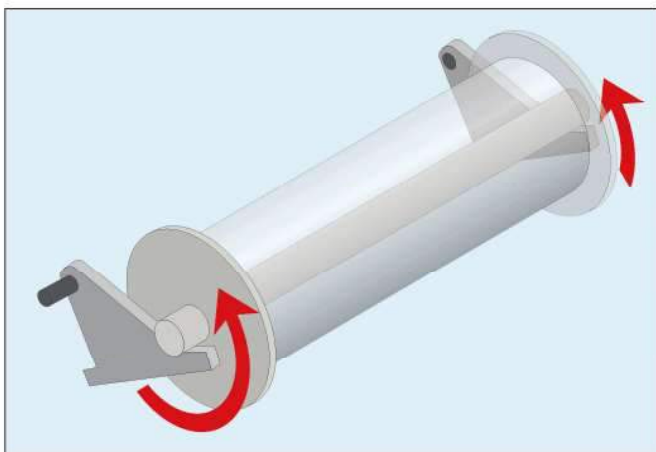

Lifting & doffing device (Option)

The arm lifting device is used when mounting or removing a warper's beam. Connection of the beam and the drive flanges is done by chucks driven by the motor.

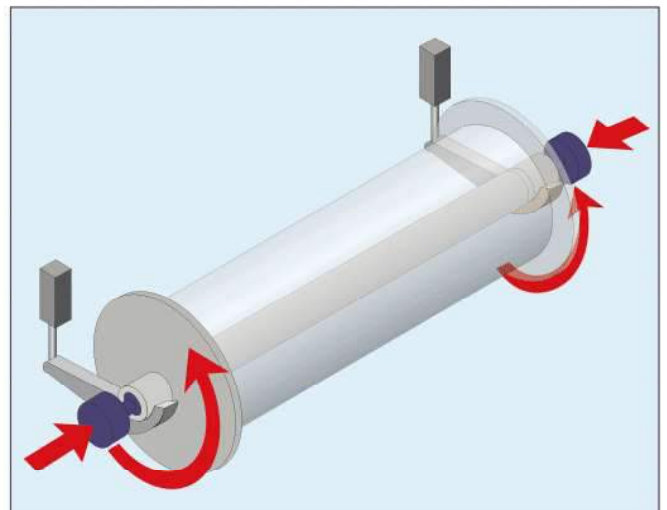

TB30F BEAMER

Developing together.

Various specifications of the pulling-out tension for the beam stand from ultra-low for super fine yarns to high tension for technical textiles are in our product lineup. The TB30F has high flexibility. Its take-up tension is in the range from 450 N to the maximum 7800 N/dia. 800 mm for high-density fabric. (Option: Tension of 300 to 5900 N/dia. 800 mm is available.)



*Accent color: Blue

Electric opening/ **NEW** closing of zigzag combs

Alignment of the yarn sheet width on the take-up beam is easy.



Tension setting & control **NEW** in increments of 1 N

Delicate yarns, such as super-fine yarns, require the tension to be set according to the yarn fineness. Setting in increments of 1 N allows finely-tuned setting and control. Stable rate of elongation is kept.

Safety measures in the **NEW** take-up section

The safety bar and the photo-electric sensor assure operator's safety.



Easy operation

The cradles on both sides are moved by independent motors to simplify mounting or removing a loom beam.

When replacing a loom beam, it can be automatically mounted or removed by hydraulic lifting device, in addition to the movement of the cradles on both sides.

Beam lifting device

The beam lifting device offers easy and safe replacement of a loom beam.



Pulling-out tension

Powder brake

60 N - 780 N

250 N - 1000 N

for thick yarns (Option)

Motor drive

40 N - 500 N

for thin yarns (Option)

20 N - 250 N

for super fine yarns (Option)

Powder brake

- Air-cooled powder brakes automatically control tension in relation to the change of section beam diameter. The brakes feature uniform and stable torque characteristics. The result is consistent uniform yarn sheet arrangement to ensure clear warp shedding on looms.
- Digital control provides a set tension even while the machine is in acceleration and deceleration.
- If a power failure occurs, the machine can be stopped without generating yarn looseness by using the uninterruptible power supply system.
- The beam stands are staggered, so that each yarn sheet is taken up in even intervals to avoid snarling.
- Individual tension control system is available to set the tension of yarns drawn from each stand individually and apply accurate feedback control.



Motor drive (Option)

- Tension is controlled based on detection by the load cell attached to the guide rolls.
- The technology of the multi-section drive employed by the sizing machine is applied to each beam stand and the take-up roll. The change gear ratio between the beam stands and the take-up roll is adjusted from moment to moment with the decrease of the winding diameter on the beam stand so that the beam stand tension meets the target value.
- Because the beams are arranged on the beam stand so that their rotating directions are alternate, warp streaks will be reduced.
- In case of a power failure, the mechanical disk brakes stop the beams in order to prevent yarns from over-running the beam to cause loose yarns.



TB30F BEAMER

Single-deck stands

Changing the beam style and handling yarns are easy.

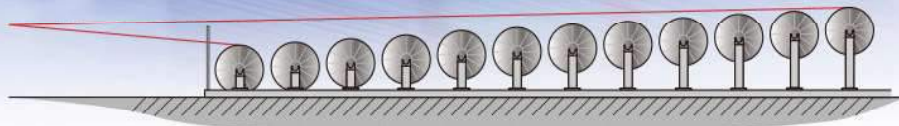

Semi-double deck stands

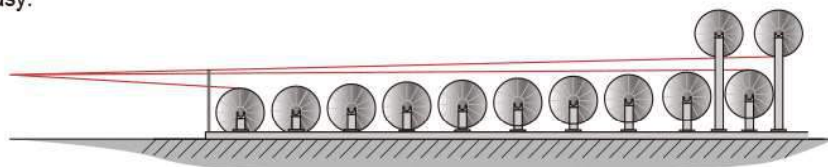

Double-deck stands

The double-deck stands are available when the installation space is limited.

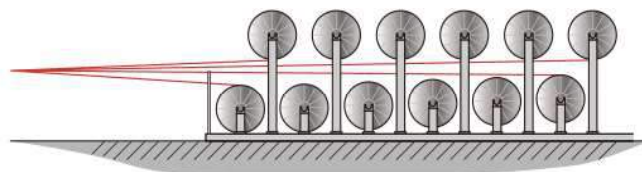

Variety of specifications are available.

Options

-Multi-point taper control for take-up tension

NEW

This taper tension control lowers the take-up tension according to the winding diameter in order to reduce loose or tight winding. With this function, users can set an arbitrary adjustment to lower the tension.

-Inverter-controlled comb traverse

Comb traverse shifts phases of the winding yarn sheet. The inverter-controlled comb traverse follows either yarn speed or winding diameter. This creates a well-arranged winding shape that results in less tension fluctuation. This is especially efficient for fine yarns.

-Yarn breakage inspector

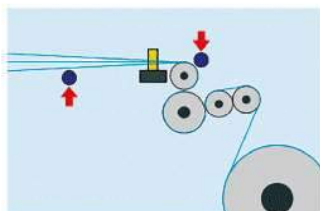

-Count-down counter

NEW

This counter stops the TB30F where there is a defect found in the previous process. Repair work will be easy.

-High-speed type with maximum 300 m/min. yarn speed

-Press roll in the take-up section

-High-tension type with maximum 10kN take-up tension

-Beam stands with guide rolls

For taking-up on a wide loom beam, beam stands with a guide roll are available to avoid forcibly pulling yarns out of each section beam.

-Independently width-adjustable beam stands

Section beams of different widths can be placed on the width-adjustable beam stands.

-Rewinding stand for a loom beam

Warp yarns are rewound under stable and high take-up tension assisted by the powder brakes.

TL LEASING MACHINE

The TL leasing machine is placed between the beam stands and the take-up section. It accurately separates the yarns up and down alternately for leasing with its hook reed. As it is operated by buttons, only one operator is required for its safe operation.

Note: The hook reed is not included. Please order it separately.



BL BEAM SETTER

The BL Beam Setter automatically mounts and removes section beams. As it requires only one operator to handle the beams easily and safely, it greatly contributes to labor saving and safety.

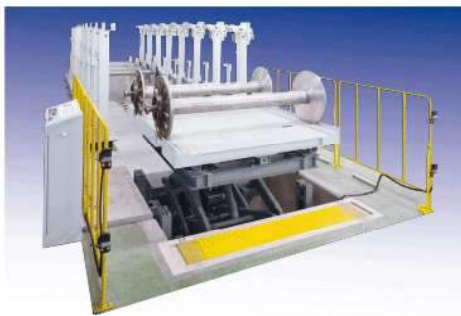

Basic motion

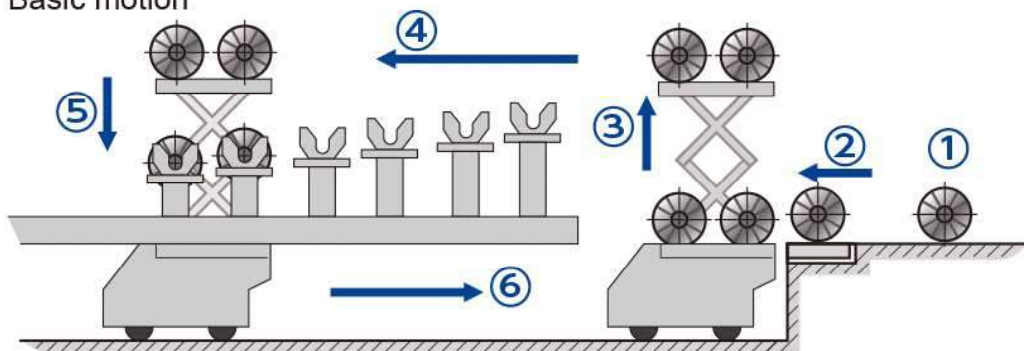

Mounting

1. The centering device aligns the centers of the beams and the beam setter.
2. An operator moves a section beam onto the beam setter.
3. The beam is fixed and the table lifter rises.
4. The beam setter moves to the specified stand position.
5. The table lifter lowers and mounts the beam onto the stand.
(For double-deck stands, the beams are provided to the upper deck first.)
6. The beam setter returns to the home position.

The above procedures are repeated until the section beams are mounted onto all the stands.

Removing

Removing is done in the reverse order of mounting. Specifying the first beam stand is not required. Removing is started from the beam stand closest to the setter.

For a 620 mm or smaller diameter beam:
two beams can be transported at one time.
For an 800 mm or larger diameter beam:
one beam is transported at one time.

TW30F WARPER

Developed to handle the yarns

The nip tension control system is employed as standard. With this system, quality warping is possible for a wide range of yarn kinds: chemical and synthetic, non-twist and high twist, and super fine to thick yarns by holding the yarns with the nip roll.



*Accent color: Blue

Tension setting & control in increments of 1 N **NEW**

Delicate yarns, such as super-fine yarns, require the tension to be set according to the yarn fineness. Setting in increments of 1 N allows finely-tuned setting and control. Stable rate of elongation is kept.

Beam inertia compensator **NEW**

The beam braking pressure appropriate for the winding diameter reduces excess tension during deceleration.

Inverter-controlled comb traverse (Option)

Comb traverse shifts phases of the winding yarn sheet. The inverter-controlled comb traverse follows either yarn speed or winding diameter. This creates a well-arranged winding shape that results in less tension fluctuation. This is especially efficient for fine yarns.

Oiling/Waxing Device (Option)

Oil or wax pick-up amount can be adjusted steplessly by changing the rotating speed of the roll with the variable speed motor. The lift bar prevents too much oil or wax from adhering to the yarns while the machine is stopped.

The automatic oil/wax supply device automatically detects the oil or wax level in the box.

High-tension type (Option)

700 m/min. – 450 N, 600 N

500 m/min. – 600 N, 800 N

Fixed-position stop system for fluff **NEW**

When any fluff, broken filament, fluff ball, or loop is detected, the machine is stopped at a fixed position. Defects on yarns are easily removed.

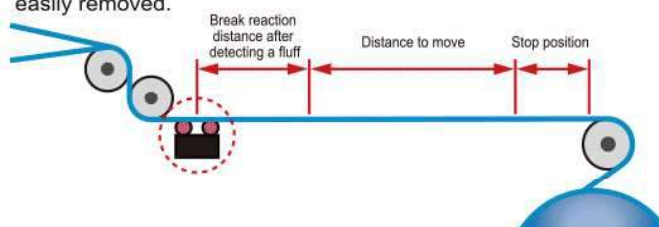

Take-up tension indicator **NEW**

The T-MDS displays the take-up tension.



Widthwise fluff position detector



Yarns determine the take-up tension controller.

Nip tension control system

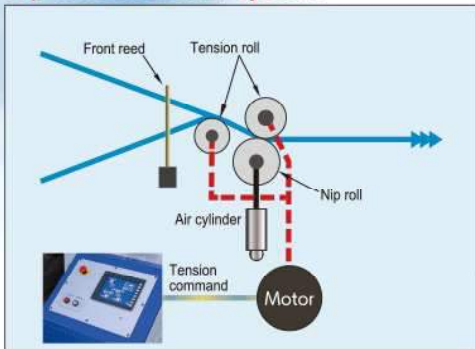

By holding the yarns with the nip roll, quality warping is possible for a wide range of yarn kinds without damaging the yarns due to slippage of the running yarns on the roll. When the warper is stopped, the nip roll positively releases the yarns immediately even during an emergency stop, so the yarns will be never damaged. The contact angle of the tension roll that is close to the creel is variable to adjust the sheet looseness after stoppage. This system responds to all yarn kinds. It is especially efficient for twisted yarns and other yarns that require winding at high tension.

Roll tension control system

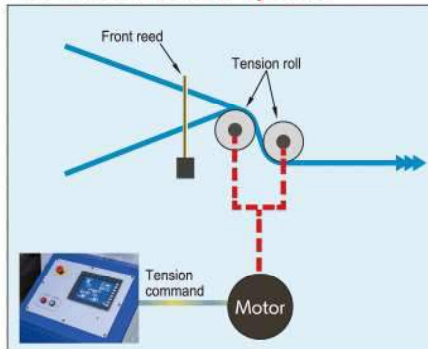

The motor that drives two tension rolls positively controls the tension. Because the roll that is close to the creel has a swing structure to change the contact angle, the friction between the yarn sheet and the roll is adjusted according to the yarn kind. This system is best for non-twist yarns.

Guide roll system

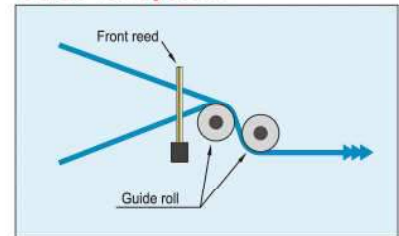

Two guide rolls negatively rotate to arrange the yarns into a sheet. The take-up tension can be adjusted with the creel tensioners. This user-friendly system is recommended for processing non-twist and low-twist yarns.

Tension control system

The take-up tension can be easily set with touch-key operation of the T-MDS with the nip tension control system and the roll tension control system. When the take-up tension control is provided, the tension is more accurately controlled by feedback control.



Super high speed warper (Yarn speed 1,000 m/min.)



*Accent color: Blue

For high speeds

Adopting the collet bush, the beam shaft can be securely held, resulting in a drive with less vibration.

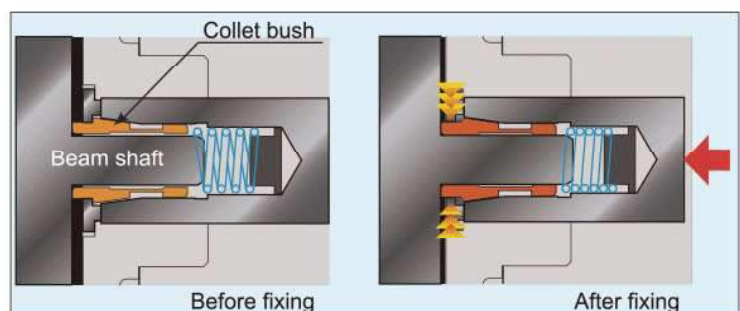

TCR-H/TCR-HT CREEL



Movable Tensioner Frame

(Standard for a spindle pitch of 310 mm or more)
The tensioner frame can be shifted easily by electric drive to align the centers of the supply packages and tensioners. Though package shapes vary according to yarn kinds, this frame makes a package holder unnecessary. The vertical movable range is 80 mm.



Movable tensioner frame

Middle Guide

Middle guides are made of alumina porcelain and are attached on every section to prevent running yarns inside the creel from interfering with each other.

When the spindle pitch is 300 mm or more and there are many rows, the middle guide is divided into two steps making its pitch about 40 mm.



Middle guide

USB-2 type stop motion Static electricity eliminator

- The static electricity eliminator is attached to the dropper section.
- The static electricity eliminator at the middle guide section is optional.



Eye guide board (Option)

The eye guide board is necessary for double creel usage. It protects the expansion comb of the warper from abrasion.



TCR-H Creel Semi-Magazine Type

Tensioner

Two kinds of tensioners, the WTP-type washer tensioner and the ring tensioner are available. Both are designed mainly for low range tension control. A third tensioner combining the features of both is also available.

WTP-type double washer tensioner

- Tension can be adjusted in a wide range.
- The surface of each disk is precisely finished and provided with mat-face hard chromium coating, minimizing weight discrepancies within $\pm 0.1\text{gr}$.
- Yarn vibration due to ballooning is reduced, preventing washers from falling off.



Ring Tensioner

- Tension is always kept stable even at low tension. It is suitable for non-sized yarn and fine denier yarn.
- Tension fluctuation due to yarn speed change is small.
- Emergency stops do not cause yarn removal.



Ring tensioner



Ring tensioner with washer (1 post)



Holder and body separate type

TCR-HT Creel Truck type



Lifter (Option)



Package holder for drum (Special design)

- Trucks with supply packages prepared in a yarn stock area are set into the creel.
- When changing large packages, preparation is easy by using a lifter.

Sizing Navigation System

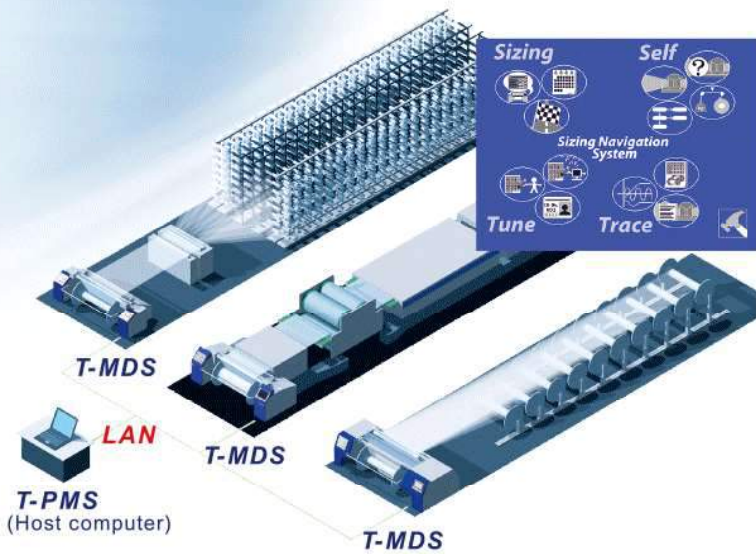

T-MDS (Machine Data Station)

All the preparatory machines (sizing machines, warpers, and beamers) employ the T-MDS computer control system with a full-color graphic display as standard. All the condition settings are available with a simple integrated touch-key operation. By registering a maximum of 300 styles in advance, operating conditions are integrated to avoid mis-operation.

T-PMS (Preparation Management System) (Option)

LAN communication (Ethernet) is possible on the T-MDS. Operation controls such as operation check, production record, and scheduling can be made easily from the host computer located in the office.

Sizing Navi®



T-MDS

Driving conditions of all the preparatory machines are observed. It is also possible to adjust the conditions. Styles can be changed by the T-PMS with a simple operation of the T-MDS. An operator can change the style scheduled by the T-PMS with a simple operation and can adjust the production order while considering the job site conditions.

T-PMS

A manager in the office can monitor the operating conditions of all the machines in the plant in real time.



Self Navi

Self-diagnosis function. A problem is quickly solved to re-start normal production.



Monitor

Operating conditions, warnings and any malfunctions are checked with an illustrated display. If a warning is given or a malfunction occurs, troubleshooting is displayed for a quick solution.

Troubleshooting

This page minutely explains countermeasures to solve any warning or malfunction.

Q & A

This page shows the solutions for minor disorders while unfolding the cause using a Q & A format.



Tune Navi

The best operating conditions are entered easily.

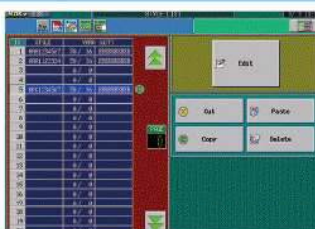

Style list

The style list data can be copied and pasted. Data control is easy.

Style Edit

It's easy to edit a style.

Style template

By entering only two to four data, such as the yarn kind and yarn quantity, the best operating conditions based on our sizing know-how can be created.



Trace Navi

The past records are traced from various viewpoints. This helps find a solution to any problem that occurs in the next process.



Sampling

Graphs the chosen data from all the items. Its colored display is helpful for quality control and feedback information of a product's defects.

Beam report, lot report

After production, a report is made. This report allows tracing the production records by beam or lot.

The screenshot shows the Trace Navi Beam report and lot report interfaces. The Beam report displays production records for individual beams, including parameters like yarn type, quantity, and quality. The lot report displays production records for entire lots, providing a comprehensive overview of production performance.

Layout Example of the Beam-to-Beam System

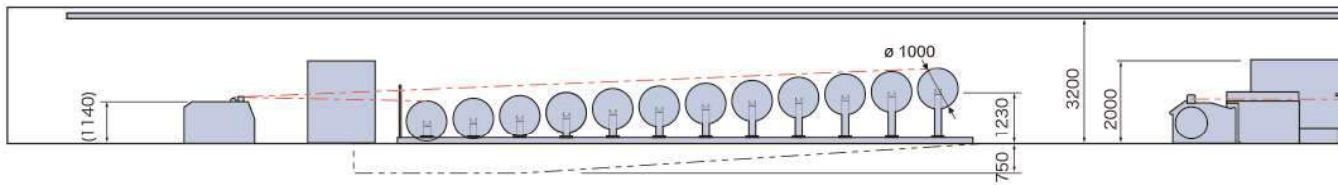
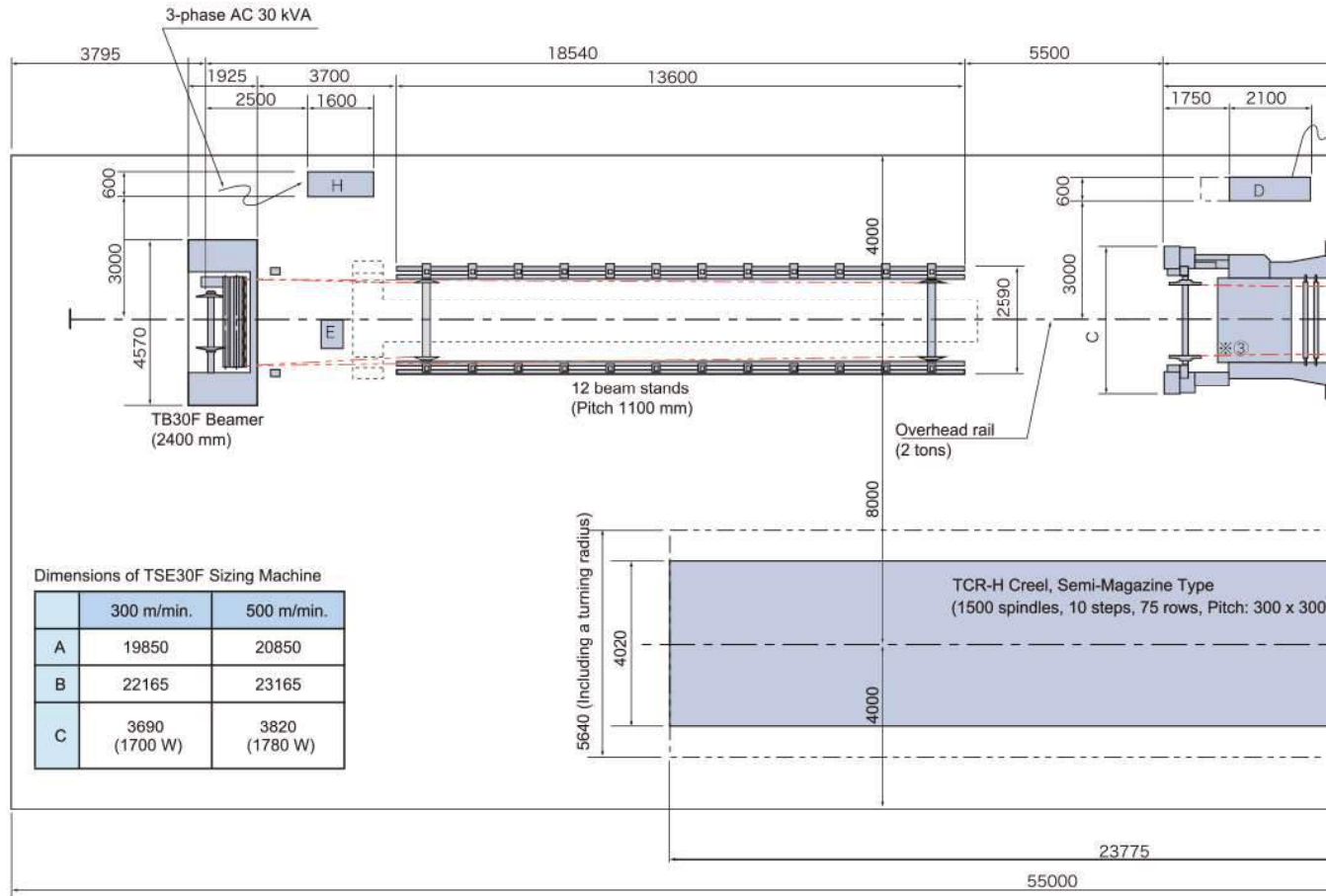

Code	Description	Code	Description
	Water faucet	F	Cavity box
※	① Warm water, washing (1/2")	G	TSD30F control box (with the lifting device)
	② Dividing rod (1/2")	H	TB30F control box
	③ Refrigerator, supply (1/2"), draining (1")	I	Size cooking operation panel
	④ Size cooking (3/4")	J	Size cooker (600 liters)
D	TSE30F control box	K	Storage tank (600 liters x 2)
E	Compressor		

SINGLE-END-SIZING SYSTEM

Unit: mm

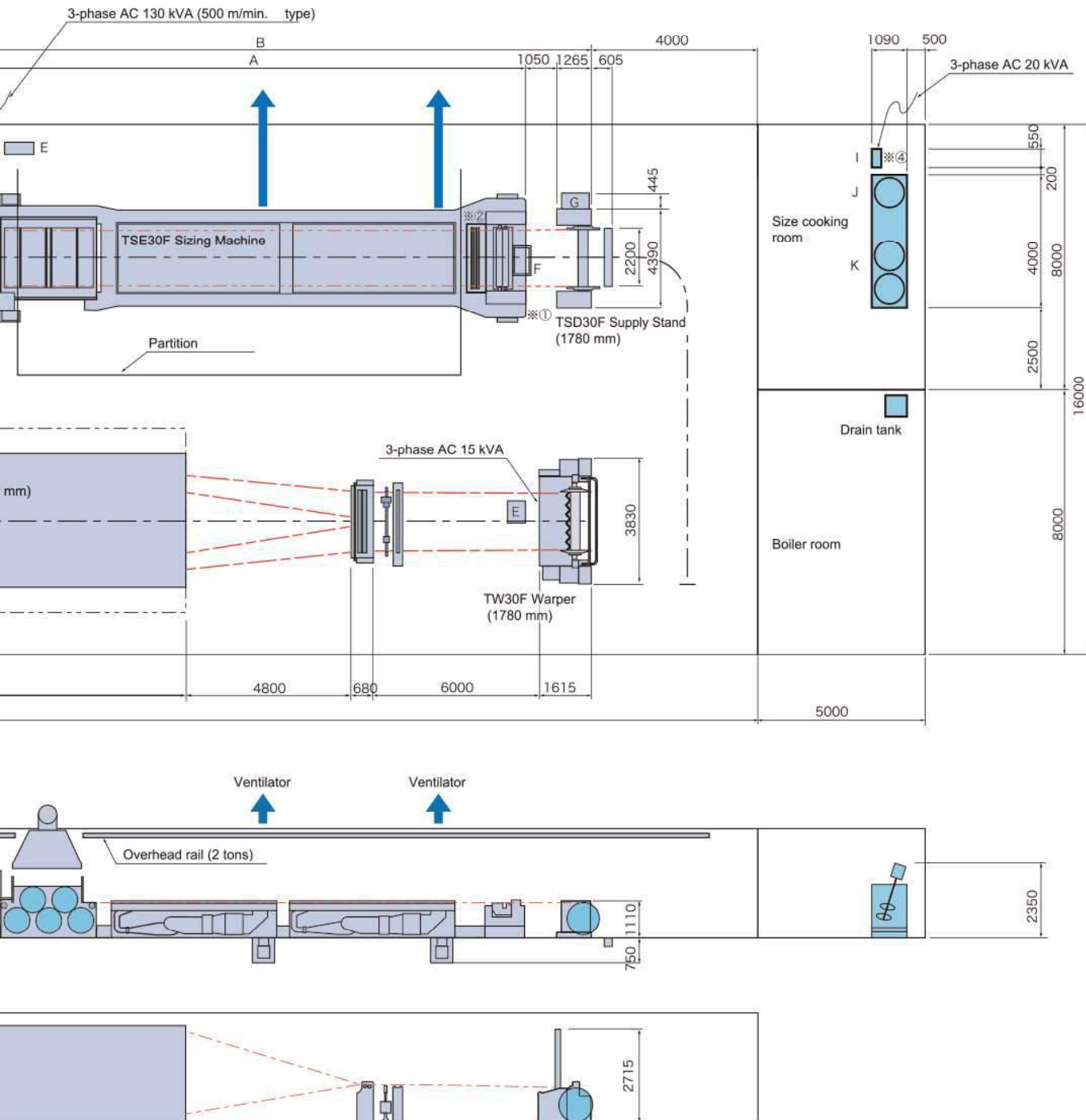

Remarks:

1. The following equipment shall be supplied by the customer.

- 1) Steam boiler: Capacity 800 kg/hour, supply pressure 0.7MPa or more
- 2) Air conditioning equipment to keep the creel and the beaming machine room at an ideal condition of 25°C temperature and 75% relative humidity.

- 3) Hood and ventilator
- 4) Water supply and drainage equipment

- 5) The following piping:
 - Steam pipe
 - Drain pipe
 - Compressed air pipe
 - Size supply pipe with stop valve
 - Material: Stainless steel (SUS304)
 - Wet air ventilation duct
 - Faucet

- 6) Overhead rail (for 2 tons)
- 7) Electric arrangements

2. The power source voltage is determined by your electric equipment.

Note: Dimensions, appearances, etc. are subject to change depending on the specifications and options.

TSE30F FILAMENT SIZING MACHINE

Maximum yarn speed		300 m/min.	500 m/min.	
Outline	Maximum warp ends to be sized	1500 ends	1500 ends	
	Production t/month (N 70 d [78 dtex], 3 shifts, 25 days, efficiency 90%)	110 t	190 t	
	Maximum sizing & drying width	1700 mm	1700 mm	
	Take-up width	1700 mm	1780 mm	1827 mm
	Stretch control	Multi-section drive system		
Take-up control section	Take-up tension control system	Tension feedback system		
	Take-up tension control range	Standard: 40 - 500 N		
		When the optional ultra-low tension control is provided: 20 - 250 N		
		When the optional high tension control is provided: 60 - 800 N		
Outer diameter of applicable flange () means an option.	800 mm (620 mm)	1000 mm (800 mm)		
Drying section	Drying system	By hot air and cylinder		
	Electric heater capacity	27+27 kW	45+27 kW	
	Temperature control system	2-step control		
	Number of cylinders (Diameter 800)	3	5	
Sizing section	Sizing system	Double squeeze system		
	Outer diameter of immersion roll	180 mm		190 mm
	Outer diameter of sizing roll	200 mm		230 mm
	Outer diameter of squeeze roll	190 mm		220 mm
	Squeeze roll structure	Uniform squeeze structure		
	Maximum squeeze pressure	15 kN		
Electric section	T-MDS computer control	Sizing Navigation System: setting and indication of various operating conditions		
Standard equipment		Tension setting & control in increments of 1 N, fluorine resin-coated tension roll in the cylinder section, humidifying system in the split section, cooling device for the control box, beam cooling device, stretch/tension control changeable device, alarm for size level in the size box, highly insulated hot-air drying chambers, auto-tuning function of temperature control for the hot-air drying chambers, hot-air drying chamber tension indicator, lightweight guide roll, air blowing controlled by inverter, cooling device		
Optional equipment		Size pump inverter, yarn speed following rotation of the water-cooled split rods, gas burner-type drying, flocked roll, count-down counter, multi-point taper control for take-up tension, inverter-controlled comb traverse, T-PMS (Preparation Management System)		
Installation capacity	Steam capacity	600 kg/H	800 kg/H	1000 kg/H
	Maximum steam consumption	400 kg/H	600 kg/H	700 kg/H
	Minimum steam supply pressure	0.7 MPa	0.8MPa	
	Electric capacity	90 kVA	130 kVA	150 kVA

TSD30F SUPPLY STAND

Stand type	Fixed or movable	Standard equipment	Low tension control (40 - 500 N)
Number of stands	Single, double (Option)		Tension setting & control in increments of 1 N
Maximum yarn speed	300 m/min., 500 m/min.	Optional equipment	Ultra-low tension control (20 - 250 N)
Beam take-up width	1700, 1780, 1827, 2000 mm		Pulling-out direction switchable function
Beam flange diameter	Maximum 1000 mm		Lifting device
Tension controller	Motor drive		Lifting & doffing device
Run-out preventer	Standard		

TB30F BEAMER

Maximum yarn speed		150 m/min.		300 m/min.	
Outline	Take-up width	2000, 2200, 2400, 2600, 2800, 3000, 3400, 3600 mm			2000, 2200, 2400, 2600, 2800, 3000 mm
	Driving motor	30 kW		45 kW	
Take-up section	Take-up system	AV-D take-up. Original system			
	Warp beam	1016 mm			
	Take-up tension range	300 - 5900 N (dia. 800 mm) 300 - 4900 N (dia. 1000 mm)	450 - 7800 N (dia. 800 mm) 450 - 7300 N (dia. 1000 mm)	400 - 5900 N	
	Beaming head	Cradle type			
	Warp beam mounting	Automatic by hydraulic cylinder and motor			
Beam stand section	Applicable beam	Maximum flange diameter 1000 mm			
	Pull-out tension range	Powder brake (one): 60 - 390 N		Powder brake (one): 100 - 390 N	
		Powder brake (two): 60 - 780 N		Powder brake (two): 100 - 780 N	
		Powder brake (two): 250 - 1000 N (Option)		-	
		Motor drive: 40 - 500 N (Option)			
Motor drive: 20 - 250 N (Option)					
Electric section	T-MDS computer control	Sizing Navigation System: setting and indication of various operating conditions			
Standard equipment		Tension setting & control in increments of 1 N (Pulling-out tension), electric opening/closing of zigzag combs, individual beam stand tension feedback control, beam lifting device, safety measures for the take-up section			
Optional equipment		Multi-point taper control for take-up tension, inverter-controlled comb traverse, yarn breakage inspector, count-down counter, cut-marking device			
Installation capacity	Minimum air pressure	0.65 Mpa			
	Electric capacity	30 kVA	40 kVA	50 kVA	

Note: The maximum tension, the maximum yarn speed, and the maximum flange diameter correlate with each other. Please consult our sales staff.

TCR-H/TCR-HT CREEL

	TCR-H				TCR-HT				
Spindle pitch (mm)	220 - 300		310 - 400		430 - 470		310 - 400	430 - 470	
Yarn package weight (Max. kg)	6		14		20		14	20	
Rows/frame	5		4		3		4	3	
Steps/frame	8	10	6	8	5	6	6	5	4

Total number of spindles: Rows x steps x number of frames x 2
 Maximum pin length: 460 mm
 Maximum cheese length: 300 mm
 Maximum outer diameter of yarn package: spindle pitch – 20 mm

Note: Drawings, data, and pictures in this brochure are subject to change for improvement without notice.

TW30F *WARPER*

Maximum yarn speed		500 m/min.	700 m/min.	1000 m/min.
Outline	Take-up width (mm)	1700, 1780, 1827, 2000		
	Take-up diameter	1000 mm		
Take-up section	Take-up system	Direct take-up, motor drive		
	Take-up tension	400 N	300 N	
	Driving motor	7.5 kW		11 kW
	Beam drive	Pin drive		Pin drive, collet chuck holding
	Beam brake	Hydraulic disk brake		
	Beam mounting/removing	Automatic operation by the brake motor and the air cylinder		
	Measuring roll	Treated with hard anodized aluminum, provided with tension detector and pneumatic disk brake		
	Catch bar	Cushion rubber		Automatic contact type with cushion rubber
	Taping device	Belt drive		
	Press roll	Pressure adjustable between 0 - 1.5 kN, with pneumatic disk brake, with the kickback device		
	Safety device	With safety bar in the take-up section		
	Accumulating device	Up roll system, maximum accumulating length 2.5 m, with push bar		(Option: 7 m)
	Tension control section	Tension control motor	2.2 kW	
Tension control range		-150 - + 250 N	-100 - + 150 N	-100 - + 150 N
Tension control system		Nip tension control		Roll tension control
Tension roll		With pneumatic disk brake, with angle adjuster		Treated with hard anodized aluminum, with angle adjuster, with pneumatic disk brake
Comb section	Creel side	Straight expansion comb or zigzag comb (selective), handle type height adjustment		Eye guide board, traverse device
	Take-up side	Zigzag comb type, manual horizontal movement, vertical and horizontal traverse = motor drive 0 - 10 mm		Zigzag comb type, manual horizontal movement, vertical and horizontal traverse = motor drive 0 - 15 mm
Electric section	T-MDS computer control	Sizing Navigation System: setting and indication of various operating conditions		
	Operation switch	Emergency stop button (One position), Run/Stop push button (Three positions)		Emergency stop button (One position), Run/Stop push button (Five positions)
Standard equipment		Tension setting and control in increments of 1 N, beam inertia compensator, fixed-position stop system for fluff, take-up tension indicator, fluff inspector		
Optional equipment		Static electricity eliminator, widthwise fluff position detector, inverter-controlled comb traverse, oiling/waxing device (kiss roll system), speed changeable-type by motor		
Installation capacity	Minimum air pressure	0.65 Mpa		0.7 Mpa
	Electric capacity	15 kVA		30 kVA

Note: Drawings, data, and pictures in this brochure are subject to change for improvement without notice.

T-Tech Japan Corp.

www.t-techjapan.co.jp

TTJ052104E